



DFG-100 XCEL

Full-Size Dual Flow Gas Convection Oven



Shown with optional casters and digital control

Project _____
Item No. _____
Quantity _____

Standard depth baking compartment - accepts five 18" x 26" standard full-size baking pans in left-to-right positions.

All data is shown per oven section, unless otherwise indicated.

Refer to operator manual specification chart for listed model name.

DFG-100 XCEL

EXTERIOR CONSTRUCTION

- Welded full angle-iron frame
- Rigid mineral fiber insulation at top, back, sides and bottom
- Stainless steel front, top, and sides for easy cleaning
- Dual pane thermal glass windows encased in stainless steel door frames
- Porcelain door handle with simultaneous door operation
- Triple-mounted pressure lock door design with turnbuckle assembly
- Modular slide out front control panel for easy access

INTERIOR CONSTRUCTION

- Double-sided porcelainized baking compartment liner (14 gauge) with coved corners for easy cleaning
- Stainless and aluminized steel combustion chamber
- Dual inlet blower wheel
- Eleven rack positions with a minimum of 1-5/8" (41mm) spacing
- Bright halogen interior lights provide optimum visibility

OPERATION

- Dual Flow Gas system combines direct and indirect heat
- Electronic spark ignition control system
- Long life inshot burners
- Toggle switch to select either 60,000 BTU or 80,000 BTU input
- Manual gas service cut-off switch on front panel
- Solid state thermostat with temperature control range of 150°F (66°C) to 550°F (288°C)
- Two speed, 3/4 horsepower, convection motor with automatic thermal overload protection
- Control area cooling fan

STANDARD FEATURES

- Solid state manual control with separate dials to control thermostat and timer
- 25" (635mm) adjustable stainless steel legs (for single units)
- 6" (152mm) adjustable stainless steel legs (for double sections)
- Draft diverter
- Flue connector (for double & additional sections)
- Porcelainized crumb pans collects cooking residues for easy oven cleaning.
- One chrome plated EZ-Slide rack with ball bearing slides capable of gliding completely out of the oven cavity. Heavy duty design holds up to 50 lbs.
- Four chrome-plated racks
- Two year oven parts and one year labor warranty*
- Five year limited oven door warranty*

* For all international markets, contact your local distributor.



BLODGETT OVEN COMPANY

www.blodgett.com

44 Lakeside Avenue, Burlington, VT 05401

Toll Free: (800) 331-5842 • Phone: (802) 860-3700 • Fax: (802) 864-0183

OPTIONS AND ACCESSORIES

(AT ADDITIONAL CHARGE)

■ Control options:

- Solid state digital control with Cook & Hold and Pulse Plus™
- Solid state digital control with Cook & Hold and Core Temperature Probe
- Solid state digital control with Cook & Hold, Pulse Plus™, and Humidair (available with stainless steel liner only)
- Blodgett IQ2™ multi-stage programmable control

■ Legs/casters/stands:

- 6" (152mm) adjustable seismic legs
- 6" (152mm) casters
- 4-1/4" (108mm) low profile casters (double only)
- 25" (635mm) stainless steel open stand with rack guides

■ Gas hose with quick disconnect and restraining device:

- 48" (1219mm) hose
- 36" (914mm) hose
- Stainless steel oven liner
- Extra EZ slide oven racks
- Extra oven racks
- Gas manifold (for double sections)
- Prison package (includes security control panel and stainless steel back)
- Stainless steel solid back panel
- Security control panel

OPTIONS AND ACCESSORIES

(AT NO CHARGE)

- Solid stainless steel doors
- Draft hood



DFG-100 XCEL

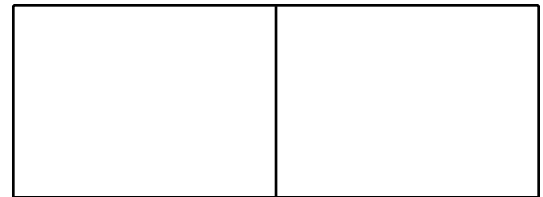

APPROVAL/STAMP

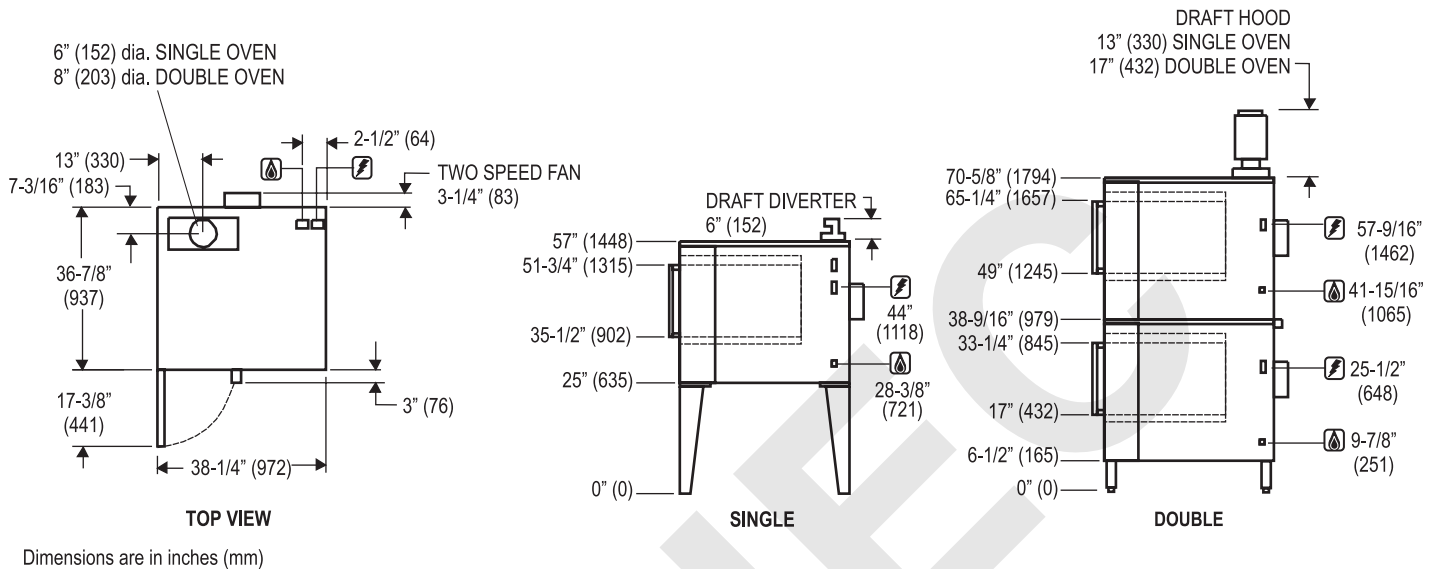

SHORT FORM SPECIFICATIONS

Provide Blodgett full-size convection oven model DFG-100 XCEL, (single/double) compartment with fully welded angle iron frame. Each compartment shall have double-sided, porcelainized or stainless steel liner. Liner to be covered top and bottom. Unit shall accept five 18" x 26" standard full-size bake pans. Stainless steel front, top and sides. Doors shall be triple mounted, stainless steel with dual pane thermal glass windows, with single porcelain handle and simultaneous operation. Unit shall be gas heated with electronic spark ignition and shall cook by means of a dual-flow system combining direct and indirect heat with a toggle switch to select either 60,000 or 80,000 BTUs. Air in baking chamber distributed by dual inlet blower wheel powered by a two-speed, 3/4 HP motor with thermal overload protection. Each chamber shall be fitted with bright halogen lamps, one chrome-plated EZ slide racks capable of holding 50 lbs, four standard chrome-plated removable racks and a two piece porcelain crumb pan. Control panel shall be recessed with Cook/Cool Down mode selector, solid state (manual/digital) infinite thermostat (150- 550°F), (66- 288°C) and 60-minute timer. Manual gas service cut-off switch on front panel. Two year oven parts and one year labor warranty and five year limited oven door warranty. Provide options and accessories as indicated.

DIMENSIONS:

Floor space	38-1/4" (972mm) W x 36-7/8" (937mm) D
Interior	29" (737mm) W x 20" (508mm) H x 24-1/4" (616mm) D
If oven is on casters add the following to all height dimensions	
Single on casters	4-1/2" (114mm)
Double on casters	2-1/4" (57mm)
Product clearance	
Oven back	0" from combustible and non-combustible construction
Oven sides	0" from combustible and non-combustible construction

MINIMUM ENTRY CLEARANCE:

Uncrated	32-1/16" (814mm)
Crated	37-1/2" (953mm)

SHIPPING INFORMATION:

Approx. Weight

Single	590 lbs. (268 kg)
Double	1095 lbs. (497 kg)

Crate sizes

37-1/2" (952mm) x 43-1/2" (1105mm) x 51-3/4" (1315mm)
(2 crates required for double)

NOTE: The company reserves the right to make substitutions of components without prior notice.

GAS SUPPLY:

3/4" NPT
Manifold Pressure:
• Natural – 3.5" W.C. • Propane – 10" W.C.
Inlet Pressure:
• Natural – 7.0" W.C. min. – 10.5" W.C. max.
• Propane – 11.0" W.C. min. – 13.0" W.C. max.

INPUT:

Single	80,000 BTU/hr (23.5 Kw)
Double	160,000 BTU/hr (47 Kw)

POWER SUPPLY:

115 VAC, 1 phase, 10 Amp, 60 Hz., 2-wire with ground,
3/4 H.P., 2 speed motor, 1725 and 1140 RPM
230, 220/240VAC, 1 phase, 3 Amp, 50 Hz., 2-wire with
ground, 3/4 H.P., 2 speed motor, 1425 and 950 RPM
6' (1.8m) electric cord set furnished on 115 VAC ovens only.
Each unit requires a dedicated 15 amp. circuit.

BLODGETT OVEN COMPANY

www.blodgett.com

44 Lakeside Avenue, Burlington, VT 05401 Toll Free: (800) 331-5842 • Phone: (802) 860-3700 • Fax: (802) 864-0183